

## GESTRA Steam Systems

Product Range B

### Level Switch Type NRS 2-40 With CAN-Bus

### NRS 2-40

#### System Description

Use level switch type NRS 2-40 in combination with level electrode type NRG 26-40 for level monitoring. The level switch has the following functions:

- Four water levels with one switchpoint each.
- High-level alarm, low-level alarm, pump ON, pump OFF, with one switchpoint each.
- Water level maintained within the control band defined by two preset limits.

The NRS 2-40 features an optional output for a standard signal 4–20 mA.

The level data are transmitted via CAN-bus from the electrode NRG 26-40 to the level switch.

#### Function

At regular intervals the level electrode type NRG 26-40 sends a data telegram to the level switch NRS 2-40. The data transfer is effected by means of a CAN bus according to DIN ISO 11898 using the CANopen protocol. The transferred measuring data are then evaluated and assigned to the switchpoints. Optionally a standard signal 4–20 mA can be allocated for external level indication. The de-energizing delay of the relay can be manually adjusted with the aid of the control terminal and display unit URB 1.

To guarantee the correct functioning and safety of the system the data transmitting cycle of the level switch is constantly monitored. When the CAN bus line is interrupted the level switch sends a visual signal to indicate a malfunction and the relays 1 and 4 will be instantaneously de-energized (fail safe position).

#### Design

##### NRS 2-40 b

Enclosure of insulating material with box terminals for installation in control cabinets. The terminals are externally accessible.

Clipping onto a standardized supporting rail TS 35 x 15 DIN EN 50022.

External dimensions: 100 x 73 x 118 mm

#### CAN-Bus

All level and temperature switches, controllers and electrodes are interconnected by means of a CAN bus. The data exchange is effected by means of a CAN bus according to DIN ISO 11898 using the CANopen protocol. Every item of equipment features an electronic address (Node ID). The four-core bus cable serves as power supply and data highway for high-speed data exchange.

NRS 2-40 is configured at our works and ready for service with other GESTRA components.

NRS 2-40 can be used straight away without having to set the node ID.

#### First and Second Control Equipment

It is possible to operate the level switch NRS 2-40 together with a **second** level switch NRS 2-40 when **8 instead of only 4 switchpoints** are required. The second level switch is termed **“second control equipment”** and must be ordered separately.

The NRS 2-40 (1st control equipment) can also be operated together with **level controller NRR 2-40** as **“second control equipment”**.

The standard equipment NRS 2-40 is designated **“first control equipment”**.

If you have any queries concerning the information included in this data sheet, please do not hesitate to contact our technical department.

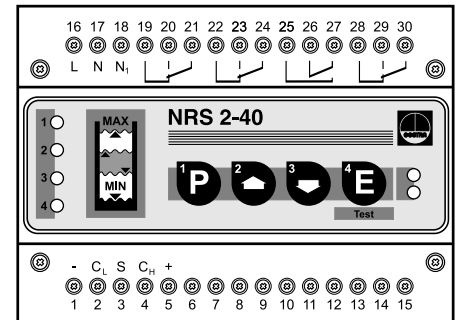

#### Important Note

Note that screened multi-core twisted-pair control cable is required, e. g. UNITRONIC® BUS CAN 2 x 2 x ...<sup>2</sup> or RE-2YCYV-fl 2 x 2 x ...<sup>2</sup>.

The baud rate (data transfer rate) dictates the cable length between the bus nodes and the total power consumption of the sensor dictates the conductor size.

S 8	S 9	S 10	Baud rate	Cable length	Number of pairs and conductor size [mm <sup>2</sup> ]
OFF	ON	OFF	250 kBit/s	125 m	2 x 2 x 0.34
Factory setting					
ON	ON	OFF	125 kBit/s	250 m	2 x 2 x 0.5
OFF	OFF	ON	100 kBit/s	335 m	2 x 2 x 0.75
ON	OFF	ON	50 kBit/s	500 m	on request, dependent on bus configuration
OFF	ON	ON	20 kBit/s	1000 m	
ON	ON	ON	10 kBit/s	1000 m	

The baud rate is set via a code switch. Reduce baud rate if cable is longer than specified in the table. Make sure that all bus nodes have the same settings.

To protect the switching contacts fuse circuit with 2.5 A (anti-surge fuse) or according to TRD regulations (1.0 A for 72 hrs operation).

# Level Switch Type NRS 2-40 With CAN-Bus

## Technical Data

### Type approval no.

TÜV · WR · 98-399

### Input

Interface for CAN bus to DIN ISO 11898, CANopen

### Output

Power supply 24 V DC, short-circuit proof.

Analogue output 4–20 mA (option),

load 500 Ω for display of actual value.

4 volt-free relay contacts.

Max. contact rating with switching voltages of

24 V AC, 115 V AC and 230 V AC: 4 A resistive,

0.75 A inductive at  $\cos \varphi 0.5$ .

Max. contact rating with a switching voltage of

24 V DC: 4 A.

Contact material: silver, hard-gold plated.

### Interference suppression

Provide contactor with external

RC combination (100 Ω - 47nF)

### De-energizing delay

Output "MIN", "MAX" 3 s

### Indicators and adjustors

1 red LED for switchpoint "MAX"

1 red LED for switchpoint "MIN"

2 green LEDs for switchpoints pump ON and pump OFF

1 green LED "Power ON"

1 red LED "Bus fault"

1 ten-pole code switch for node ID and baud rate,

4 pushbuttons

### Supply voltage

230 V +/- 10%, 50/60 Hz

115 V +/- 10%, 50/60 Hz (option)

24 V +/- 10%, 50/60 Hz (option)

### Power consumption

5 VA

### Protection

Case: IP 40 to DIN EN 60529

Terminal strip: IP 20 to DIN EN 60529

### Admissible ambient temperature

0 °C to 55 °C

### Enclosure material

Front panel: polycarbonate, grey

Case: polycarbonate, black

### Weight

Approx. 0.8 kg

## Order and Enquiry Specification

GESTRA Level Switch type NRS 2-40 CANopen

Control equipment .....

Mains voltage .....V

## Ancillary Units

■ Capacitance level electrode type NRG 26-40  
CANopen

■ Level switch NRS 2-40 CANopen as second control  
device for 8 switchpoints

■ Level controller NRR 2-40 CANopen as second  
control device for modulating level control

Supply in accordance with our general terms  
of business.

## Dimensions

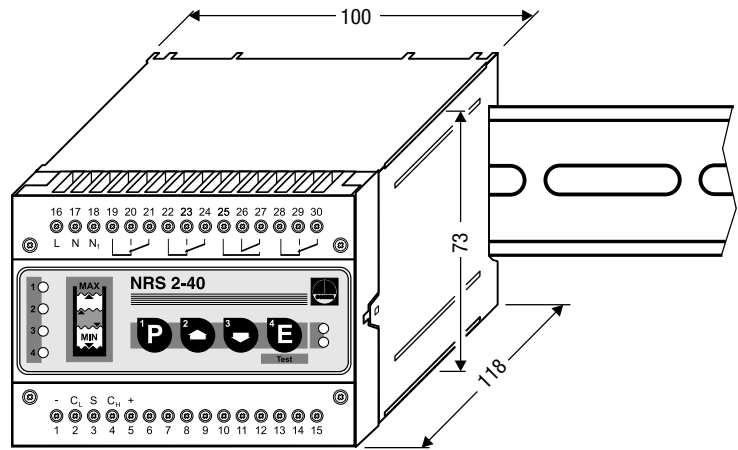
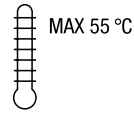

## Wiring Diagram

### Fill control

with High-level cut-out function

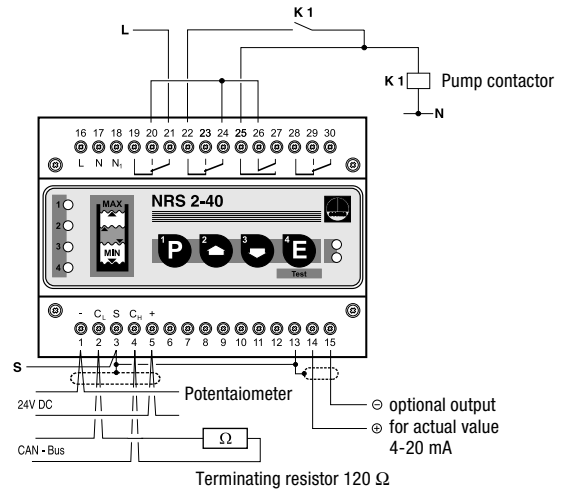

### Discharge control

with Low-level cut-out function

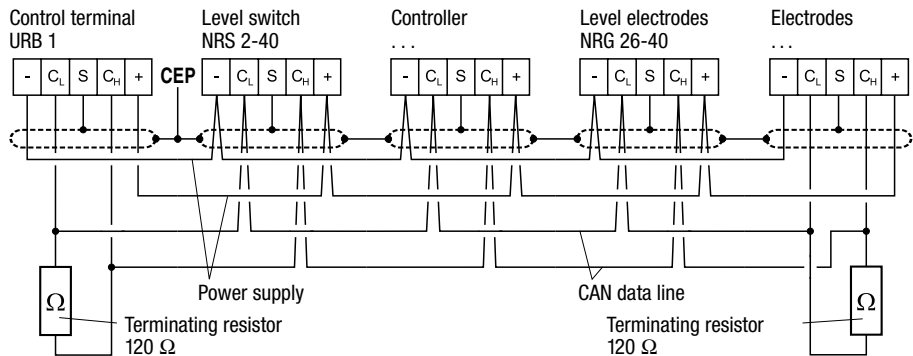
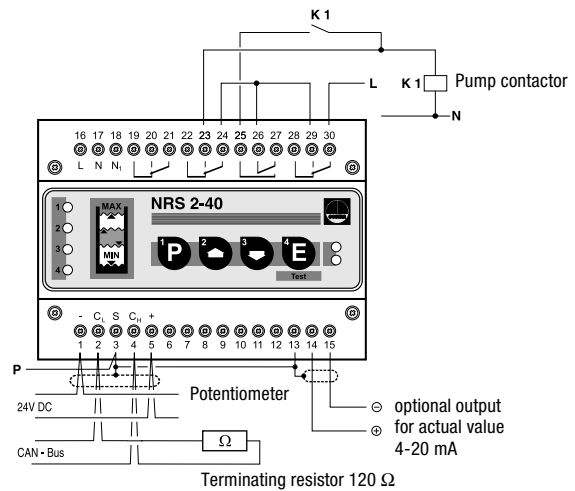

# GESTRA AG

P. O. Box 10 54 60, D-28054 Bremen

Münchener Str. 77, D-28215 Bremen

Telephone +49 (0) 421 35 03 -0, Fax +49 (0) 421 35 03 - 393

E-Mail [gestra.ag@flowserve.com](mailto:gestra.ag@flowserve.com), Internet [www.gestra.de](http://www.gestra.de)

